



Your team is compact, quick and efficient.

This is why our printers are, too.

When you really need a good, dependable, compact colour printer that's simple, fast, affordable and can take care of all your team's daily requirements without wasting valuable office space; you need the DX-C200P network colour printer.



NETWORK PRINT

DUPLEX

DX-C200P Digital Full Colour Printer

Performance your team can count on

Look around. Everyone's busy; efficiency is everything. So you need to get the best possible use from every resource. With print speeds of up to 20 pages per minute in full colour as well as in black & white, that's exactly what the DX-C200P delivers.

The first page appears just 14 seconds after clicking on 'Print', and automatic two-sided printing is standard, so everyone gets what they need with less waiting around. Plus, you can add an extra paper drawer to increase the paper supply right the way up to 750 sheets – a real bonus for busy teams.

Special jobs are no problem either, thanks to a bypass tray for feeding non-standard media.



Effortless efficiency

Vibrant colour and an interpolated 2400 x 600 dpi print resolution add clarity and style to everything you print. A powerful controller and plenty of memory make light work of your larger, more complex jobs.

Every workgroup should have a DX-C200P colour printer. Thanks to a space-saving design and a combination of PCL, PostScript 3 emulation, IPv6, Bonjour and seamless integration with every common office environment, every workgroup can.

We've made sure that it's easy to use, too. A Web Image Monitor keeps constant track of the DX-C200P, letting you view its status and settings from anywhere on the network, and there's a raised display screen which also tells you all you need to know about the printer's toner, paper and operational readiness. Time, energy, toner and paper all come at a cost. If you're as passionate about conservation as we are, then the Energy Star-certified DX-C200P is exactly the right printer for you.

The energy-saving design with low power consumption, rapid warm up, and a fast first page out time all help to save time and money. High-yield, all-in-one toner brings further savings (especially when you use the Economy Colour Mode), the combination of double sided printing and N-up print can greatly reduce paper consumption and there's an energy-saving 'sleep' setting for periods of inactivity.



Specifications

| GENERAL | |
|----------------------------------|--|
| Type | Desktop |
| Engine Speed (ppm) (Max) | A4 |
| Colour | 20 |
| B/W | 20 |
| Paper size | Max. A4, min. A6 |
| Paper weight (g/m ²) | |
| Drawer | 60 – 160 |
| Bypass | 60 – 160 |
| Optional Drawer | 60 – 105 |
| Paper capacity (Std – Max) | |
| Sheets | 250 - 270 (plus 1 sheet bypass tray) |
| Drawers | 1 - 2 (plus 1 sheet bypass tray) |
| Warm-up time*1 (seconds) | 30 |
| First print out time*2 (seconds) | |
| Full colour | 14 |
| B/W | 14 |
| Memory (MB) | 256 |
| Power requirements | 230-240V AC, 50/60 Hz |
| Power consumption (Max) | 1.3 kW |
| Dimensions (mm) (W x D x H) | 400 x 450 x 320 |
| Weight (kg) | 23.8 |
| NETWORK PRINTER | |
| Resolution (dpi) | 600 x 600, 1200 x 600, 2400 x 600*4 |
| Interface | USB 2.0, 10Base-T/100Base-TX |
| Supported OS | Windows® XP, Windows® Server 2003/2003R2/2008/2008R2, Windows® Vista, Windows® 7 Mac OS X 10.3 - 10.6 |
| Network protocols | TCP/IP (IPv4, IPv6), IPP, Bonjour |
| Printing protocols | LPR, Raw TCP (port 9100), FTP, IPP |
| PDL emulation Std | PCL5c/6, PS3 |
| Available fonts PCL/PS | 80/80 |

*1: At rated voltage. May vary depending on machine conditions and operating environment.

*2: Best achieved time based on A4, 600 x 600 dpi. May vary depending on machine conditions and operating environment. *3: Best achieved time based on A4, at 25°C. May vary depending on machine conditions and operating environment. *4: Resolutions higher than 600 dpi are interpolated.

*5: Based on 8 x 3.85 line/mm, 33.6 kbps, MMR, ITUT#1 chart.

- Design and specifications are subject to change without prior notice. • Colour variations to products may occur due to printing. • Some features require optional items. Please consult with an authorised Sharp reseller for details. • All information and technical details are correct as at machine release date.
- Windows and Windows Vista are registered trademarks of Microsoft Corporation in the United States and/or other countries. • All other brand names and product names may be trademarks or registered trademarks of their respective owners.
- The ENERGY STAR logo is a certification mark and may only be used to certify products that have been determined to meet the ENERGY STAR programme requirements. ENERGY STAR is a US registered mark. The ENERGY STAR guidelines apply to products only in the US, the EU, Japan, Canada, Australia, New Zealand and Taiwan.

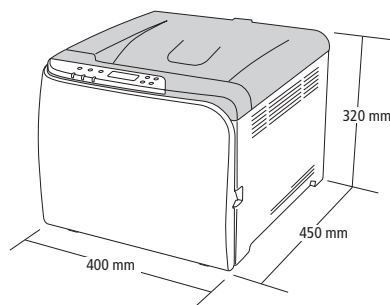

SHARP

SHARP CORPORATION OF AUSTRALIA PTY LTD
ABN 40 003 039 405
1 Huntingwood Drive, Huntingwood NSW 2148
P.O. Box 6827, Blacktown, NSW 2148
Tel: (02) 9830 4600 Fax: (02) 9672 1208
www.sharp.net.au